

PRODUCT SPECIFICATIONS

ET157-N-12060 Height Adjustable Desk



SPECIFICATIONS

- Height range: 730-1180mm
- Max. Load capacity: 50KG
- Max. Lifting Speed: 15mm/s
- Noise: <50db
- Reserved/ 2-stage / oval / slender column design
- Six-key Handset (up and down keys + four height memory keys)
- N.W.: 20.8KG G.W.: 23.4KG
- Product outer box dimensions and packing quantity:
1285*670*140mm (1 package)
564 pieces (40HQ)

Default Handset (GM30 motor integrated handset)



Column tube section

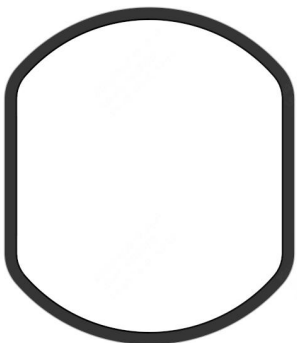

Product Line drawing

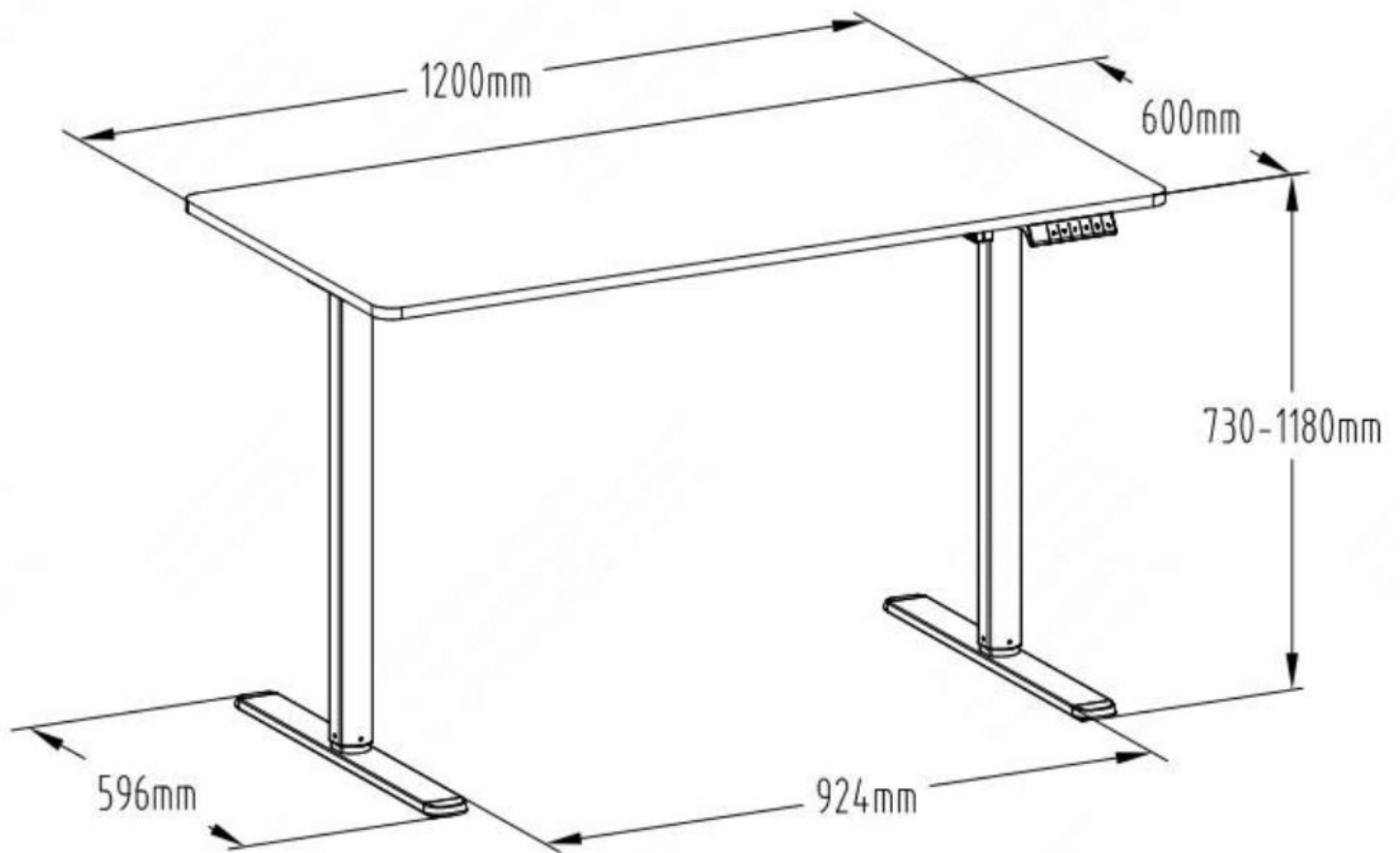

Model: ET157-N-12060

Desktop:1200x600x16mm(particle board)

Height Adjustable Range:

730-1180mm

Stroke: 450mm

Max. speed: 15mm/s

Max. Load capacity: 50kg

Outer oval tube: 58x50x1.5mm

Inner oval tube: 53x45x1.5mm